



**KAYMAKÇILAR**  
DÖKÜM ve SANAYİ A.Ş.  
Casting & Machining Industry

[www.kaymakcilar.com.tr](http://www.kaymakcilar.com.tr)



- Toplam Alan: 18.000 m<sup>2</sup>
- Kapalı Alan: 7.500 m<sup>2</sup>
- 3 x Otomatik kalıplama Hattı
- 3 x Ergitme Ocağı
- Otomatik Döküm Sistemi
- 6 x Maça makinesi ve tam otomatik dozajlama
- Tam otomatik kum hazırlama sistemi
- Laboratuvar
- Boya Atölyesi
- Paketleme Atölyesi

- Total AREA is 18.000 m<sup>2</sup>
- Closed Area is 7.500 m<sup>2</sup>
- 3 x Automatic Molding Lines
- 3 x Melting Furnaces
- Auto Pouring System
- 6 x Core Making Machines and full automatic dosing
- Full Automatic Sand Preparation System
- Laboratory
- Paint Shop
- Packing Yard

## Hakkımızda About Us

1976 yılında üretim hayatına başlayan ve şu anda Ankara Başkent Organize Sanayi Bölgesinde faaliyetine devam eden firmamızın üretim konuları Lamel Grafitli Demir Döküm, Küresel Grafitli Demir Döküm ve Talaşlı İmalattır.

Our company established in 1976. Our company continues its activities at the moment Ankara Baskent Organized Industrial Zone. Our company's main production Lamellar Graphite Iron Castings, Ductile Iron Castings and Machining.



[www.kaymakcilar.com.tr](http://www.kaymakcilar.com.tr)

## Misyonumuz Our Mission

Döküm sektöründe edinilmiş bilgi ve tecrübeleri gelecek kuşaklara aktaran, teknolojisinde sürekli gelişimi sağlayan, rekabetçi yapısıyla iş ortakları ve ülke ekonomisi için değer üreten, topluma ve çevreye karşı duyarlı, sürdürülebilir bir dinamizm yaratmaktadır.

Our Mission is to create a sustainable dynamism that is environmentally conscious and socially responsible, while carrying our experience and know-how in the foundry sector over to future generations, maintaining a continuous development in our technologies, creating values for business partners and the economy of the country with our competitive nature.

## Vizyonumuz Our Vision

Sürekli büyüme anlayışı ile kapasitesini etkin kullanan, kaliteden ödün vermeyen, geliştirme faaliyetlerine önem veren, pik ve sfero döküm üretiminde sektör lideri, dünya tedarikçisi bir firma olmaktır.

is to become industry leading company, a global supplier, in nodular cast iron and gray cast iron production, one that is making an efficient use of our capacities, not compromising on quality, and placing emphasis on our development operations.

- Toplam Alan : 3.600 m<sup>2</sup>
- Kapalı Alan : 2.200 m<sup>2</sup>
- 7 x Yatay İşleme Merkezi
- 3 x Dik İşleme Merkezi
- 4 x Yatay Torna
- 3 x Dik Torna
- 3D-CMM Koordinat Ölçüm (Nikon)
- Lazer Markalama
- Parça Yıkama

- Total AREA : 3.600 m<sup>2</sup>
- Closed Area : 2.200 m<sup>2</sup>
- 7 x Horizontal Machining Center
- 3 x Vertical Machining Center
- 4 x Horizontal Lathe
- 3 x Vertical Lathe
- 3D-CMM Machine (Nikon)
- Lazer Marking
- Industrial Parts Washer



## “Biz” Olmak Becoming “us”

Farkı yaratan sandır. İşini seven, yetenekli ve vizyon sahibi bir grup olarak yaptığımız işlerde fark yaratıyoruz. Paylaştıkça büyüyeceğimize inanıyor, kurumlarımızın gerçek sahibinin çalışan herkes olduğunu bilerek daha verimli ve daha üretken olabiliyoruz. Birbirimizin uzmanlığına saygı gösteriyor ve birbirimize güveniyoruz. Grup olarak elde edilen başarı da, bireysel başarılar da, hepimizin başarısıdır düşüncesiyle “biz bir aileyiz” bilinciyle çalışıyoruz. Tedarikçilerimizi, ürün ve hizmet ürettiğimiz müşterilerimizi de “biz” anlayışıyla aileden kabul ediyoruz.

People make the difference. As a talented and visionary group that loves its job, we make a difference in the work we do. We believe that we will grow by sharing and we can be more efficient and productive by acknowledging that the true owners of our corporations are everybody who work for them. We respect each other's expertise and we trust each other. We work with an understanding that “we are a family” and both the successes we achieve as a group and as individuals belong to all of us. We consider our suppliers and our customers for whom we provide goods and services with an understanding of “us”, as members of our family...



## Saygı ve Bağlılık Respect and Commitment

İşimizi en doğru şekilde, gönülden sahiplenerek yapıyoruz. Tüm ilişkilerimizi saygı ve sevgi çerçevesinde kuruyoruz, bu sayede güvene dayalı uzun vadeli birliktelikler oluşturuyoruz. Tutarlıyız, verdiğimiz sözleri mutlaka yerine getiriyoruz.

We do our job in the best possible way with a devoted dedication. We build all our relations within the framework of love and respect, this way we build long term partnerships based on trust. We are consistent, we keep our promises no matter what.



## Ar-ge R&D

Müşterilerimizin ve dahil olduğumuz sektörlerin ihtiyaçlarını göz önüne aldığımızda, ürettiğimiz ürünün ve hizmetlerin var olanlardan daha iyi olması için, devamlı araştırma yapıyoruz. Eğitimler ve sürekli gelişme sayesinde müşterilerimize yeni ve akılcı olanaklar sunuyoruz.

When we take the needs of our customers' and industries' needs into consideration; we constantly conduct studies to improve our existing goods and services. We can offer new and smart possibilities to our customers thanks to training and constant improvement.



## Sürdürülebilir Büyüme Respect and Commitment

Değişime uyum sağlayacak stratejiler geliştiriyoruz. Mevcut işlerimizi en iyi şekilde yapmaya devam ederken, sektörleri sürekli takip ediyor, yeni pazarlar ve ürünlerle büyümeye devam ediyoruz.

We develop strategies that can adapt to change. While continuing to maket he most of our existing work, we constantly monitor the industries and continue to grow through new markets and goods.

ISO 9001-2015



ISO 45001-2018



ISO 14001-2015



CE - 2014/68/EU  
(Pressure Equipment)



# Döküm Simülasyonu

## Casting Simulation

**Kusursuz Geometri, Güvenilir Mikroyapı: Döküm Simülasyon Teknolojimiz**  
Modern döküm sanayi, sadece eritmek ve dökmekten ibaret değildir; her molekülün ve her boşluğun önceden hesaplanmasıdır. Fabrikamızda, özellikle üretimi yüksek hassasiyet ve uzmanlık gerektiren Sfero (Küresel Grafitleşmiş) Döküm parçalar başta olmak üzere, tüm kritik projelerimizi ileri düzey Döküm Simülasyon Programları ile dijital dünyada test ediyoruz.

**Perfect Geometry, Reliable Microstructure: Our Casting Simulation Technology**  
Modern foundry industry is not just about melting and pouring; it is the precise pre-calculation of every single molecule and shrinkage cavity. At our foundry, we test all our critical projects—especially Ductile (Nodular) Iron Castings, which require high precision and expertise—in the digital environment using advanced Casting Simulation Software.

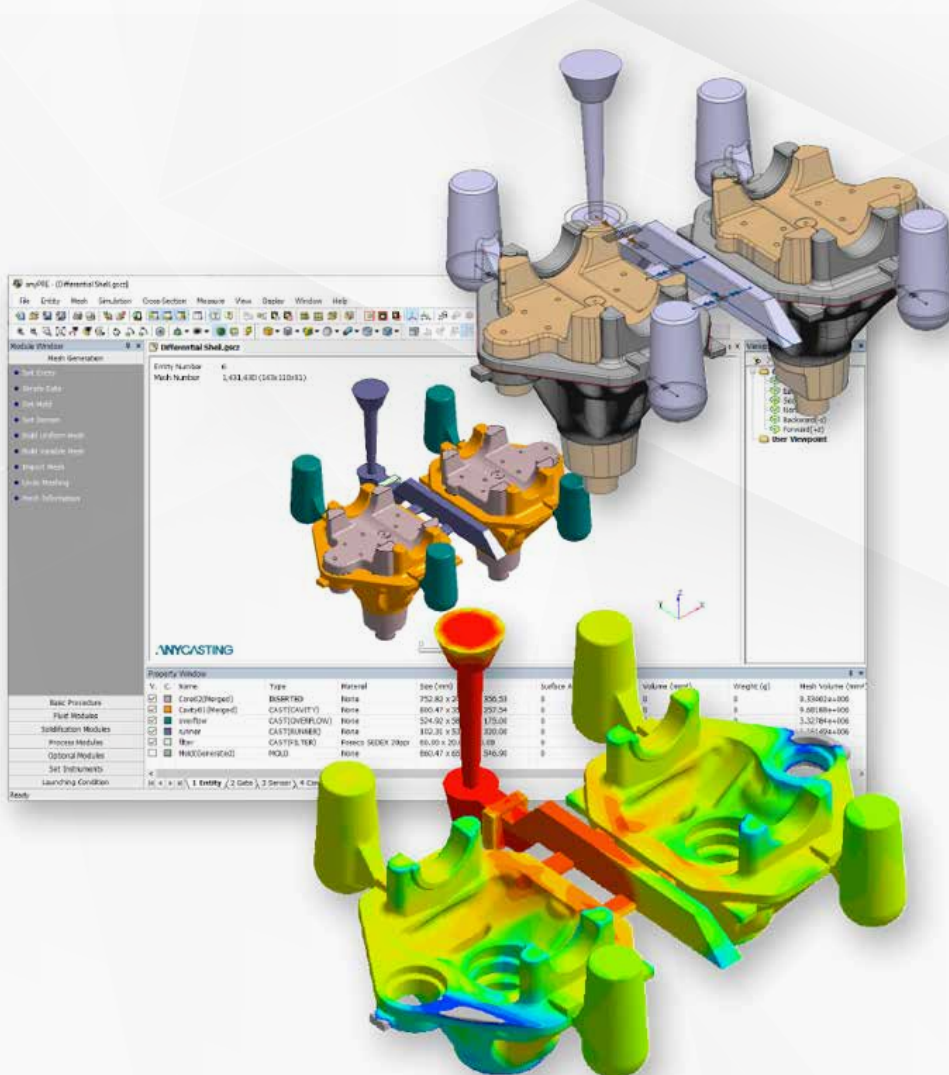

# Laboratuvar

- Spektrometre (ARL-ThermoFischer) – 2 cihaz
- Çekme Test Cihazı
- Mikroyapı Analizi – Yazılım Destekli
- Kum analizleri
- HBN Sertlik Ölçüm Cihazı
- QuikLab E
- Ultrasonic Hata Dedektörü



# Laboratory

- Spectrometer (ARL-Thermofischer) - 2 machines
- Tensile Strength Testing Machine
- Microstructure Analysis - With Software
- Sand Analysis
- HBN Hardness Test Machine
- QuikLab E
- Ultrasonic Flaw Detector



# Ocaklar ve Kapasite

## Furnaces & Capabilities

- 2 x 6 ton ergitme ocağı (duet-track)
- 2 x 1,5 ton ergitme ocağı (dual-track)
- 1 x 1 ton ergitme ocağı (power-track)
- Yıllık Döküm Kapasitesi : 45.000 ton

- 2 pcs x 6 tons melting furnaces (Duet-track)
- 2 pcs x 1,5 tons melting furnaces (dual-track)
- 1 pcs x 1 ton melting furnace (power-track)
- Annual casting capacity : 45.000 tons



**GRİ DÖKME DEMİR**  
**GREY CAST IRONS**

- EN GJL 200
- EN GJL 250
- EN GJL 300

**SFERO DÖKME DEMİR**  
**NODULAR CAST IRONS**

- EN GJS 350-22
- EN GJS 400-15
- EN GJS 400-18
- EN GJS 450-10
- EN GJS 500-7
- **EN GJS 500-10**
- EN GJS 600-3
- **EN GJS 600-10**



## Tasarım, Model ve Fikstür İmalatı

- Model ve maça sandıkları Kaymakçılar Ar-Ge ekibi tarafından dizayn edilir.
- AGMA CNC (X-Y-Z : 1900 – 1000 – 800 mm)'de imal edilir.
- Tüm Talaşlı İmalat Fikstürleri bünyemizde yapılmaktadır.



## 3D Design – Pattern Making – Fixture Making

- Patterns and core boxes are designed by Kaymakçılar R&D team
- Made on AGMA CNC (X-Y-Z : 1900 – 1000 – 800 mm)
- Machining fixtures are made in Kaymakçılar facility

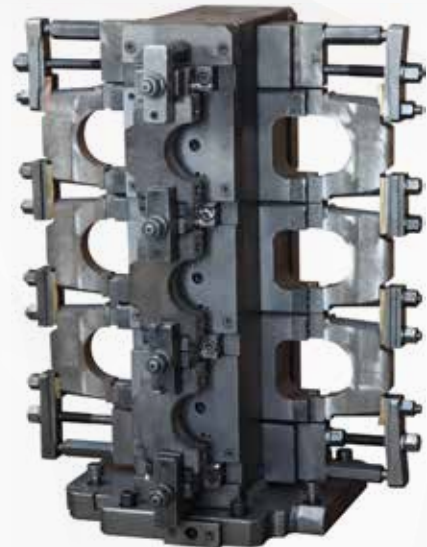
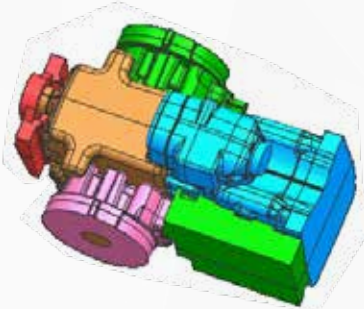
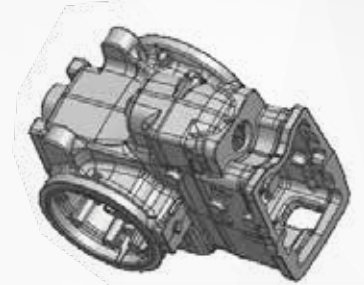
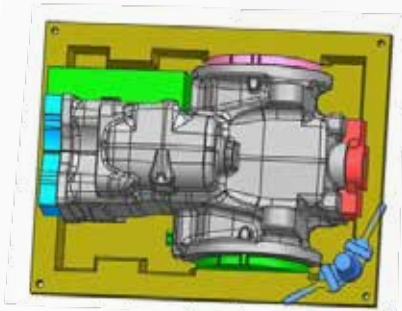
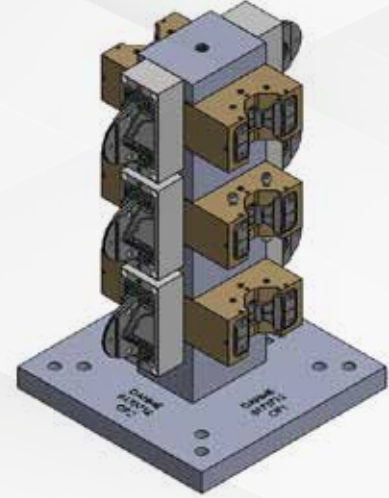

# Kalıplama Hatları

## Molding Lines

### SINTO FBO – III

- Ölçüler : 500 x 600 x (200+200) mm
- Kalıplama hızı : 90 kalıp/saat
- Maksimum Döküm Ağırlık : 40 Kg

- Dimensions : 500 x 600 x (200+200) mm
- Molding Speed : 90 molds/hour
- Maximum casting weight : 40 Kg



### SINTO FCMX – III

- Ölçüler : 600 x 700 x (250+250) mm
- Kalıplama hızı : 200 kalıp/saat
- Maksimum Döküm Ağırlık : 90 Kg

- Dimensions : 600 x 700 x (250+250) mm
- Molding Speed : 200 molds/hour
- Maximum casting weight : 90 Kg



# Kalıplama Hatları

## Molding Lines

### Künkel Wagner

- Ölçüler: 800 x 1000 x (350+350) mm
- Kalıplama hızı: 15 kalıp/saat
- Maksimum Döküm Ağırlık: 300 Kg

- Dimensions: 800 x 1000 x (350+350) mm
- Molding Speed: 15 molds/hour
- Maximum casting weight: 300 Kg



# Otomatik Döküm Sistemi

## Auto Pouring System

- 0,5 – 1 Ton Döküm Kapasitesi
- 15 sn/kalıp Döküm Hızı
- Otomatik Pota Değişimi
- Seviye Kontrolü için Termal Kamera
- Entegre Toz Aşılama Ünitesi

- Molten metal capacity : 0,5 – 1 Ton
- Casting speed : 15 sn/mold
- Automatic ladle change
- Thermal camera for level control
- Integrated inoculation unit



# Maça Üretimi

- Tam otomatik dozaj sistemi
- Soğuk Kutu
- 3 x 10 Lt
- 2 x 20 Lt
- 1 x 85 Lt
- Maça kurutma fırını



# Core Production

- Automatic dosing system
- Cold Box
- 3 x 10 Lt
- 2 x 20 Lt
- 1 x 85 Lt
- Core drying oven

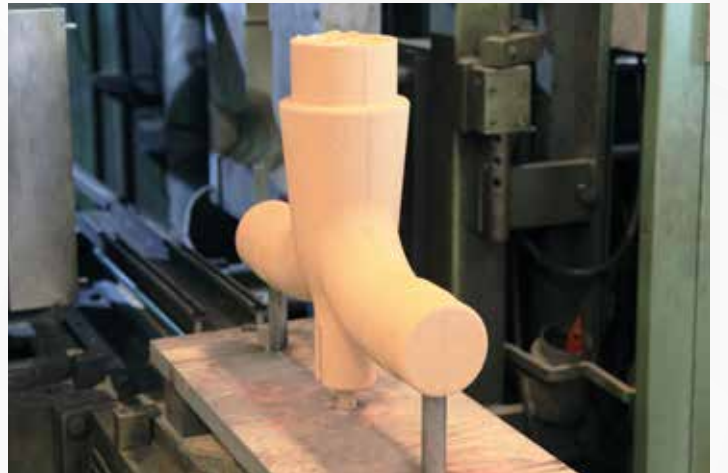
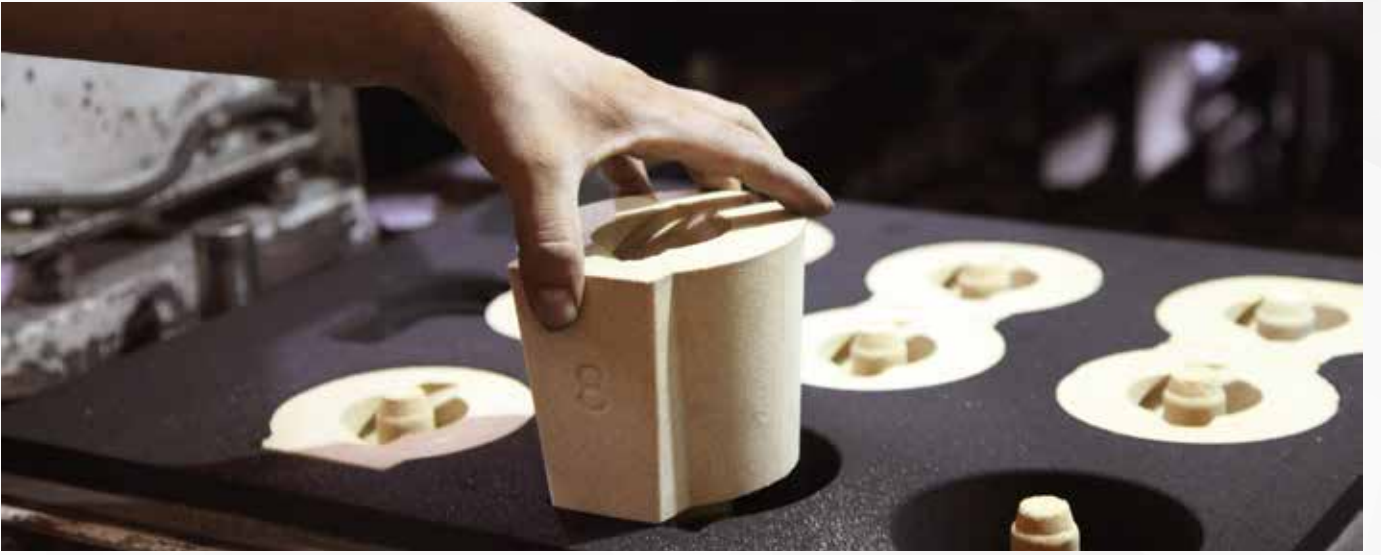

# Talaşlı İmalat

- 7 x Yatay İşleme Merkezi
- 3 x Dik İşleme Merkezi
- 4 x Yatay Torna
- 3 x Dik Torna
- 3D-CMM Koordinat Ölçüm (Nikon)
- Lazer Markalama
- Parça Yıkama



MAKİNA

# Machining

- 7 x Horizontal Machining Center
- 3 x Vertical Machining Center
- 4 x Horizontal Lathe
- 3 x Vertical Lathe
- 3D-CMM Machine (Nikon)
- Lazer Marking
- Industrial Parts Washer

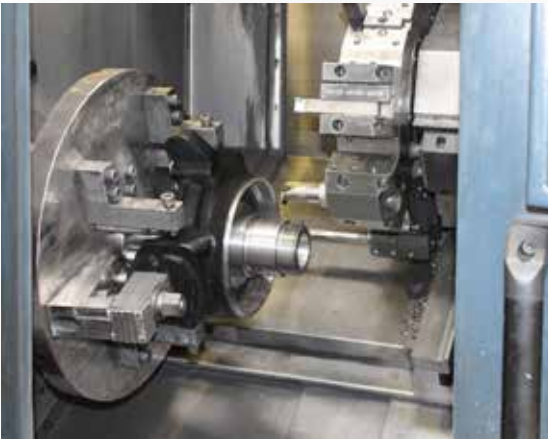

## Sektörler Sectors



Tarım Makinaları – Agriculture Industry



Redüktör – Gear Units



Pompa & Vana – Pumps & Valves



Kompresör – Compressors



Demiryolları – Railways



Savunma Sanayi – Defence Industry

## Ürün Fotoğrafları Product Photos



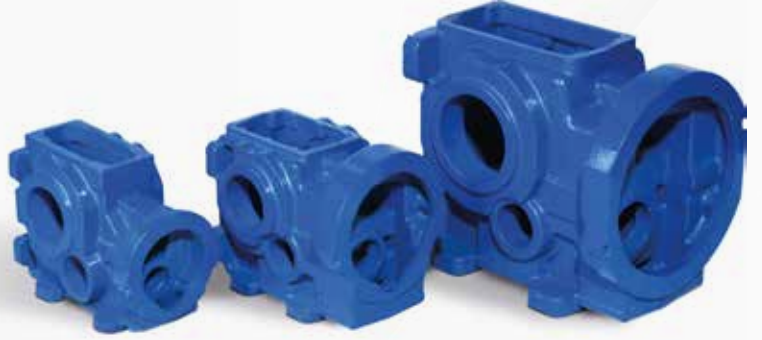







Online Catalog



www.fikrialeajans.com | 0312 394 63 83

**KMD** KAYMAKÇILAR  
DÖKÜM ve SANAYİ A.Ş.

📍 Başkent OSB 16. Cadde No: 17 Malıköy-Sincan / ANKARA-TÜRKİYE

✉ info@kaymakcilar.com.tr • ☎ +90 312 640 12 90

[www.kaymakcilar.com.tr](http://www.kaymakcilar.com.tr)